

# Charlke®

## CONTRACTOR®



## ROTARY HAMMER DRILL

MODEL NO: CON1200RD

PART NO: 6479600

## OPERATION & MAINTENANCE INSTRUCTIONS

UK  
CA | CE



ORIGINAL INSTRUCTIONS

GC1023 - ISS 6

---

## INTRODUCTION

---

Thank you for purchasing this CLARKE Hammer Drill. The CON1200RD is designed for general drilling/masonry drilling/chiselling/drill & hammer use in light industrial applications.

Before attempting to use this product, please read this manual thoroughly and follow the instructions carefully. In doing so you will ensure the safety of yourself and that of others around you, and you can look forward to your purchase giving you long and satisfactory service.

---

## GUARANTEE

---

This product is guaranteed against faulty manufacture for a period of 12 months from the date of purchase. Please keep your receipt which will be required as proof of purchase.

This guarantee is invalid if the product is found to have been abused or tampered with in any way, or not used for the purpose for which it was intended.

Faulty goods should be returned to their place of purchase, no product can be returned to us without prior permission.

This guarantee does not effect your statutory rights.

---

## INVENTORY

---

1	Moulding plastic carrying case	7	Pot of Grease
2	Rotary Hammer Drill	8	8mm SDS+ masonry drill bit
3	Front Handle	9	10mm SDS+ masonry drill bit
4	13 mm Drill Chuck Adaptor	10	12mm SDS+ masonry drill bit
5	Chuck Key	11	2 x SDS+ plus masonry chisel bits
6	Dust Shield Cup		

---

# SAFETY PRECAUTIONS

---



**WARNING: READ ALL INSTRUCTIONS. FAILURE TO FOLLOW ALL INSTRUCTIONS LISTED BELOW MAY RESULT IN ELECTRIC SHOCK, FIRE AND/OR SERIOUS INJURY. THE TERM "POWER TOOL" IN ALL WARNINGS LISTED BELOW REFERS TO YOUR HAMMER DRILL.**

---

## WORK AREA

1. **Keep work area clean and well lit.** *Cluttered and dark areas invite accidents.*
2. **Do not operate power tools in explosive atmospheres, such as in the presence of flammable liquids, gases or dust.** *Power tools create sparks which may ignite the dust or fumes.*
3. **Keep children and bystanders away while operating a power tool.** *Distractions can cause you to lose control.*

## ELECTRICAL SAFETY

1. **Avoid body contact with earthed or grounded surfaces such as pipes, radiators, ranges or refrigerators.** *There is an increased risk of electric shock if your body is earthed or grounded.*
2. **Do not expose power tools to rain or wet conditions.** *Water entering a power tool will increase the risk of electric shock.*
3. **When operating a power tool outdoors, use an extension cord suitable for outdoor use.** *Use of a cord suitable for outdoor use reduces the risk of electric shock.*

## PERSONAL SAFETY

1. **Stay alert, watch what you are doing and use common sense when operating a power tool. Do not use a power tool while you are tired or under the influence of drugs, alcohol or medication.** *A moment of inattention while operating power tools may result in personal injury.*
2. **Use safety equipment. Always wear eye protection.** *Safety equipment such as dust mask, non-skid safety shoes, or hearing protection used for appropriate conditions will reduce personal injuries.*
3. **Avoid accidental starting. Ensure the switch is in the off position before connecting to the power supply.**
4. **Do not overreach. Keep proper footing and balance at all times.** *This enables better control of the power tool in unexpected situations.*

5. **Dress properly. Do not wear loose clothing or jewellery. Keep your hair, clothing and gloves away from moving parts.** *Loose clothes, jewellery or long hair can be caught in moving parts.*

## **POWER TOOL USE AND CARE**

1. **Do not force the power tool. Use the correct power tool for your application.** *The correct power tool will do the job better and safer at the rate which it was designed.*
2. **Do not use the power tool if the switch does not turn it on and off.** *Any power tool that cannot be controlled with the switch is dangerous and must be repaired.*
3. **Disconnect the battery before making any adjustments, changing accessories, or storing power tools.** *Such preventive safety measures reduce the risk of starting the power tool accidentally.*
4. **Store idle tools out of the reach of children and do not allow persons unfamiliar with the power tool or these instructions to operate the power tool.** *Power tools are dangerous in the hands of untrained users.*
5. **Maintain power tools. Check for misalignment or binding of moving parts, breakage of parts and any other condition that may affect the power tools operation. If damaged, have the power tool repaired before use.** *Many accidents are caused by poorly maintained power tools.*
6. **Keep cutting tools sharp and clean.** *Poorly maintained cutting tools with sharp cutting edges are less likely to bind and are easier to control.*
7. **Use the power tool and accessories in accordance with these instructions and in the manner intended for the particular type of power tool, taking into account the working conditions and the work to be performed.** *Use of the power tool for operations different from intended could result in a hazardous situation.*







## **SERVICE**

1. **Have your power tool serviced by a qualified repair person using only identical replacement parts.** *This will ensure that the safety of the power tool is maintained.*

---

## SAFETY SYMBOLS

---

	Read instruction manual before use		Wear dust mask
	Class 2 Double Insulated		Wear ear defenders
	Weee Directive		Wear safety glasses

---

## ENVIRONMENTAL RECYCLING POLICY

---



Through purchase of this product, the customer is taking on the obligation to deal with the WEEE in accordance with the WEEE regulations in relation to the treatment, recycling & recovery and environmentally sound disposal of the WEEE.

In effect, this means that this product must not be disposed of with general household waste. It must be disposed of according to the laws governing Waste Electrical and Electronic Equipment (WEEE) at a recognised disposal facility.

## ELECTRICAL CONNECTIONS



**WARNING: READ THESE ELECTRICAL SAFETY INSTRUCTIONS THOROUGHLY BEFORE CONNECTING THE PRODUCT TO THE MAINS SUPPLY.**

Before switching the product on, make sure that the voltage of your electricity supply is the same as that indicated on the rating plate. Connecting it to any other power source may cause damage.

If it is necessary to change the fuse in the plug, the fuse cover must be refitted. If the fuse cover becomes lost or damaged, the plug must not be used until a suitable replacement is obtained.

If the plug has to be changed due to damage, a replacement should be fitted, following the wiring instructions shown below. The old plug must be disposed of as insertion into a mains socket could cause an electrical hazard.



**WARNING: THE WIRES IN THE POWER CABLE OF THIS PRODUCT ARE COLOURED IN ACCORDANCE WITH THE FOLLOWING CODE:  
BLUE = NEUTRAL    BROWN = LIVE**

If the colours of the wires in the power cable of this product do not correspond with the markings on the terminals of your plug, proceed as follows.

- The **Blue** wire must be connected to the terminal marked **N** or coloured **Black**.
- The **Brown** wire must be connected to the terminal marked **L** or coloured **Red**.

**Plug must be BS1363/A approved.**

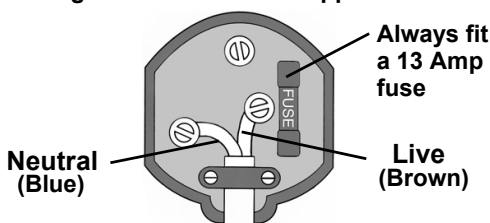

**Ensure that the outer sheath of the cable is firmly held by the clamp**

**We strongly recommend that this machine is connected to the mains supply via a Residual Current Device (RCD)**

If in any doubt, consult a qualified electrician. DO NOT attempt any repairs yourself.



**This symbol indicates that this is a Class II product, and does not require an earth connection.**

# OVERVIEW

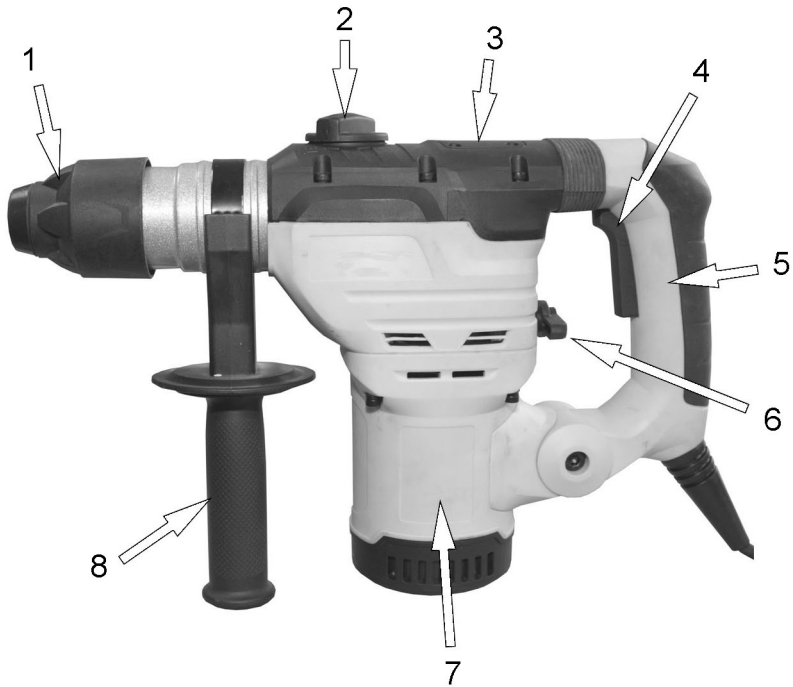

NO	DESCRIPTION	NO	DESCRIPTION
1	SDS+ Chuck	5	Rear Handle
2	Rotation Stop Switch	6	Hammer Action Selector
3	Grease Port Cover	7	Motor
4	Trigger	8	Front Handle

---

## BEFORE USE

---

### INSERTING A DRILL BIT / CHISEL

The chuck clamps SDS+ drill bits and chisels without the need for a chuck key.

1. Pull back the collar.
2. Insert the bit
3. Turn the bit in the chuck until it latches.
4. Release the collar to lock in place.
5. Check by pulling the bit to see if it is locked in place.

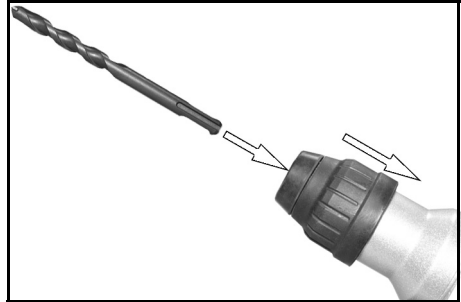

**IMPORTANT:** Always clean the shaft of the drill bit before inserting into the chuck.

**IMPORTANT:** Do not allow dust or debris inside the chuck as this will cause problems in the future.

### REMOVING A BIT

1. Slide the collar to the rear and pull the bit out of the chuck.



CAUTION: WHEN REMOVING A BIT FROM THE DRILL, REMEMBER THAT IT MAY BE EXTREMELY HOT. EITHER ALLOW IT TO COOL DOWN FIRST OR USE INDUSTRIAL GLOVES TO REMOVE THE BIT.

---

### USING THE DRILL CHUCK ADAPTOR (DRILL MODE ONLY)

When drilling with non SDS+ drill bits, a 13mm chuck (supplied) can be inserted into the SDS+ chuck as shown.

**IMPORTANT: DO NOT USE THE CHUCK ADAPTER IN HAMMER ACTION MODE.**

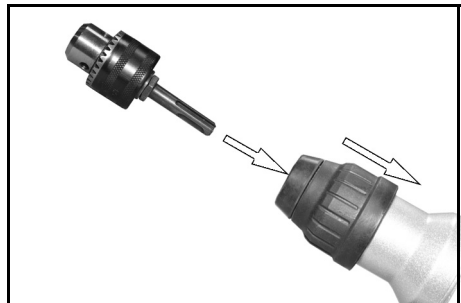



## POSITIONING THE FRONT HANDLE

The front handle can be positioned left, right or centre as required.

1. Loosen the handle by twisting it clockwise (when viewed from above).
2. Rotate the handle to the required position.
3. Secure the handle by twisting it anticlockwise (when viewed from above).

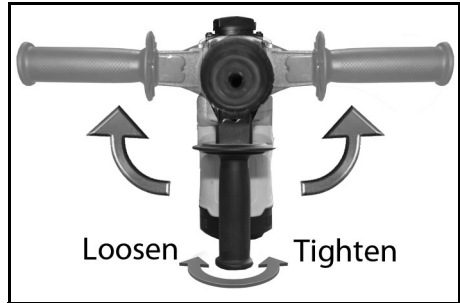

## SELECTING THE OPERATING MODE

Mode	Hammer Action selector	Rotation selector
Drill Only	Drill Only	ON
Hammer Drill	Hammer Assisted Drilling	ON
Hammer only (no rotation)	Hammer Assisted Drilling	OFF

### HAMMER ACTION SELECTOR

1. With the drill not operating, set the hammer action selector to the required setting.
  - Left - Hammer Assisted Drilling
  - Right - Drill Only

**IMPORTANT:** When using the "hammer action" you only need to apply light pressure. Too much pressure will place unnecessary load on the motor. Check the drill bits regularly, re-sharpen or replace if required.

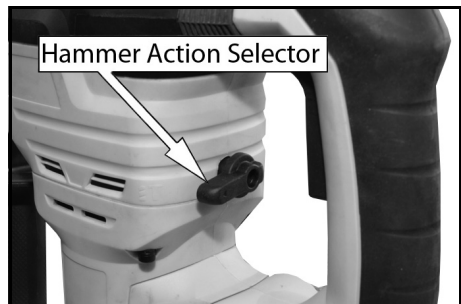

## ROTATION ON/OFF SELECTOR

Some jobs require the chuck to remain stationary yet still have the hammer effect, such as chiselling concrete, plaster etc.

- Set the rotation selector to the right for "no rotation".
- Set the rotation selector to the left for "normal rotation".

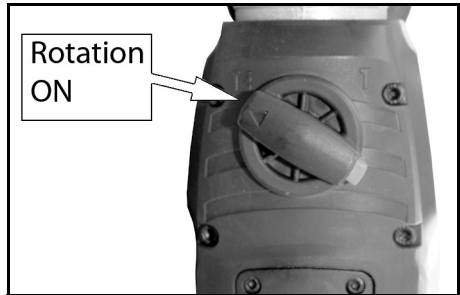
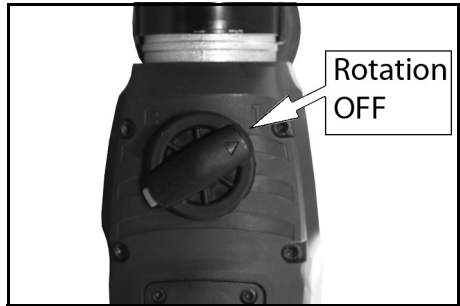

---

## USING THE DRILL

---

### BEFORE STARTING WORK

1. Before drilling into walls and floors etc., check first that there are no hidden electrical cables, gas or water pipes etc.
2. Check the mains voltage before plugging in and switching on.
3. Ensure the work area is as hazard free as possible.

### STARTING WORK

1. Select and install the bit to be used. See page 8.
2. If required, adjust the support handle attachment for the most comfortable position. See page 9.
  - For safety, always use the hammer drill with the front handle attached.
3. Set the required operating mode. See page 9.
4. When drilling vertically overhead, fit the rubber dust shield cup shown onto the drill bit.



5. Position the tool against the surface to be drilled and pull the trigger switch.
  - If using the hammer action do not start the drill until the tool is in contact with the work surface.



### STOPPING WORK

1. Release the trigger and wait until the bit has stopped before placing the drill on any surface

## DRILLING TIPS

- Always use sharp, good quality drill bits. The performance of your drill is dependant on the quality of the bits used.
- After drilling material to the full depth, do not simply pull out the drill but maintain chuck rotation to ease withdrawal.
- Reduce the pressure on the drill bit when it is about to break through. This will prevent the drill from jamming.
- If drilling a large hole, first drill a pilot hole using a smaller drill bit.
- Always apply pressure to your drill bit in a straight line and, where possible, at right angles to the workpiece.
- When drilling in metal, the materials being drilled can become hot. To reduce overheating use a suitable cooling lubricant. No cooling lubricant is necessary when drilling cast iron or brass as they should be drilled dry.
- When drilling metal, the harder the metal the slower the drill speed. Similarly, the bigger the drill bit the slower the speed.
- To prevent the drill bit from slipping when starting to drill a hole in metal, use a centre punch to make an indentation at the start point.
- Always start drilling at a slow speed to prevent the drill from slipping out of the pop mark or indent, gradually increasing speed until the optimum cutting speed is achieved whilst maintaining a MODERATE pressure ONLY. NEVER force the drill bit into the work. This will overheat the tip and cause it to dull very quickly.
- When drilling in wood, clamp a piece of scrap wood to the underside of the material to avoid splintering.
- Large holes should be drilled with wood augers, flat wood bits or hole saws.

---

## DRILL BITS

---

A wide choice of SDS+ and standard drill bits are readily available for this drill.

Please contact your local stockist or visit the Clarke website at:  
[www.clarkeinternational.com](http://www.clarkeinternational.com)

---

## MAINTENANCE AND SERVICING

---

1. After use, remove the drill bit and tap the side of the chuck to remove any dust or chippings etc.
2. Keep the handle clean and free from oil and grease.
3. Worn or damaged parts must be replaced by qualified personnel.
4. Clean the tool regularly, use a soft brush and or soft cleaning cloth. DO NOT use any chemicals or harsh abrasives to clean the tool.
5. At the end of work, to prevent dust deposits you should use compressed air (max.3 bar) to clean out the ventilation holes.

### GEARBOX GREASE

Check gearbox occasionally and top up if necessary with a good quality high melting point grease.

1. Remove the 4 hex bolts from the grease cover.
2. Remove the cover.
3. Apply sufficient grease to cover all visible moving parts.
  - DO NOT overfill the gearbox.
4. Replace the cover and hex bolts before using the drill again.

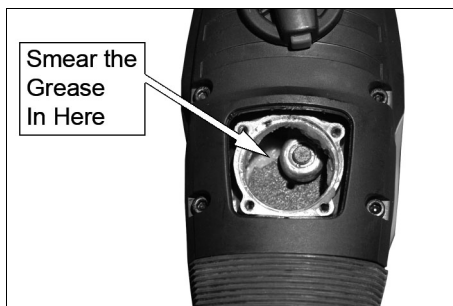

## SPECIFICATIONS

Operating voltage and frequency	230V AC~ 50Hz -1phase
Rated input power	1200W
Chuck capacity/type	SDS+ Plus 13mm keyed chuck adapter
Rotational speed	Drill Mode 860 rpm Drill/Hammer Mode 820 rpm
Impact rating	4050 (blows/min)
Maximum drilling capacity	Wood - 42 mm, Steel - 13 mm, Concrete - 32 mm
Sound Pressure Level	96.4 dB LpA
Sound Power Level	107.4 dB LWA
Vibration	Rotary hammer - 19.327 m/s <sup>2</sup> Chiselling hammer - 17.879 m/s <sup>2</sup>
Weight	4.7 kg
Dimensions (L x H x W)	410 x 275 x 105 mm
Duty Cycle classification	S1 (continuous)

# PARTS DIAGRAM

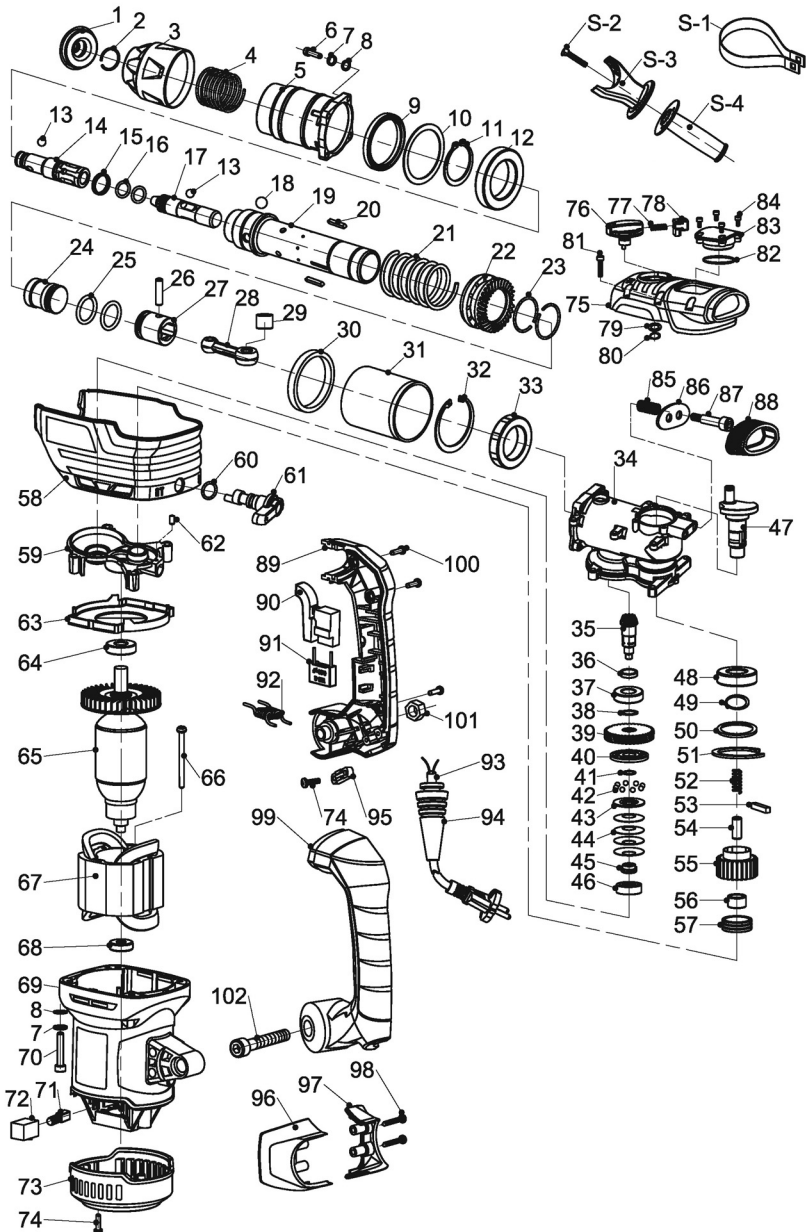

## PARTS LIST

ID	DESCRIPTION	ID	DESCRIPTION
1	Rubber Cap	31	Cylinder Case
2	Circlip	32	Circlip
3	Chuck Grip	33	Bearing
4	Spring	34	Gearbox
5	Chuck Barrel	35	Small Gear
6	Screw	36	Washer
7	Washer	37	Bearing
8	Washer	38	Washer
9	Oil Seal	39	Gear
10	Washer	40	Fixing Plate
11	Circlip	41	Washer
12	Bearing	42	Ball
13	Ball	43	Plate
14	Flex	44	Spring
15	X-ring	45	Nut
16	O-ring	46	Bearing
17	Impact Hammer	47	Eccentric Shaft
18	Ball	48	Bearing
19	Cylinder	49	Washer
20	Flat Key	50	Washer
21	Spring	51	Washer
22	Drive Gear	52	Spring
23	Circlip	53	Flat Key
24	Hammer	54	Spindle
25	O-ring	55	Gear
26	Piston Pin	56	Needle Bearing
27	Piston	57	Impact Bolt Holder
28	Connecting Rod	58	Centre Cover
29	Needle Bearing	59	Middle Cover
30	O Ring	60	O-ring



<b>ID</b>	<b>DESCRIPTION</b>	<b>ID</b>	<b>DESCRIPTION</b>
61	Hammer Action Selector	84	Screw
62	Screw	85	Spring
63	Retainer	86	Anti-vibration Board
64	Bearing	87	Screw
65	Rotor	88	Anti-vibration Cover
66	Screw	89	Right Handle moulding
67	Stator	90	Trigger
68	Bearing	91	Capacitor
69	Motor Casing	92	Inductor
70	Screw	93	Power Cable
71	Brush	94	Cable Sheath
72	Brush Holder	95	Cable Board
73	Brush Cover	96	Left Hand Handle Sheath
74	Screw	97	Right Hand Handle Sheath
75	Upper Cover	98	Screw
76	Rotation Selector	99	Left Handle moulding
77	Spring	100	Screw
78	Button	101	Nut
79	Washer	102	Socket Head
80	Washer 14	S1	Hoop
81	Screw	S2	Screw
82	O-ring	S3	Bracket
83	Cover	S4	Handle/grip

# DECLARATION OF CONFORMITY - UKCA



# Clarke<sup>®</sup> INTERNATIONAL

Hemnall Street, Epping, Essex, CM16 4LG

## DECLARATION OF CONFORMITY

**This is an important document and should be retained.**

**We hereby declare that this product(s) complies with the following legislation:**

*The Electromagnetic Compatibility Regulations 2016*

*The Supply of Machinery (Safety) Regulations 2008*

*The Restriction of the Use of Certain Hazardous Substances in Electrical and Electronic Equipment Regulations 2012*

**The following standards have been applied to the product(s):**

*EN 61000-3-3:2013+A1:2019+A2:2021, IEC 62321-4:2013+AMD1:2017 CSV, EN IEC 55014-1:2021,*

*EN IEC 62841-2-6:2020+A11:2020, EN IEC 61000-3-2:2019+A1:2021, EN 62841-1:2015+A11:2022,*

*EN IEC 55014-2:2021, IEC 62321-7-1:2015, IEC 62321-7-2:2017, IEC 62321-3-1:2013,*

*IEC 62321-1:2013, IEC 62321-2:2013, IEC 62321-5:2013, IEC 62321-6:2015, ISO 17075-1:2017*

The technical documentation required to demonstrate that the product(s) meet(s) the requirement(s) of the aforementioned legislation has been compiled and is available for inspection by the relevant enforcement authorities.

**The UKCA mark was first applied in: 2021**

**Product Description:** Rotary Hammer Drill  
**Model Number(s):** CON1200RD  
**Serial/Batch Number:** Refer to product/packaging label  
**Date of Issue:** 26/10/2023

**Signed:**

**J.A Clarke**

**Director**

# DECLARATION OF CONFORMITY - CE



**Clarke**<sup>®</sup>  
**INTERNATIONAL**

Fitzwilliam Hall, Fitzwilliam Place, Dublin 2

## DECLARATION OF CONFORMITY

**This is an important document and should be retained.**

**We hereby declare that this product(s) complies with the following legislation:**

2014/30/EU                      *Electromagnetic Compatibility Directive*  
2006/42/EC                    *Machinery Directive*  
2011/65/EU                    *Restriction of Hazardous Substances (RoHS) Directive*

**The following standards have been applied to the product(s):**

*EN 61000-3-3:2013+A1:2019+A2:2021, IEC 62321-4:2013+AMD1:2017 CSV, EN IEC 55014-1:2021,  
EN IEC 62841-2-6:2020+A11:2020, EN IEC 61000-3-2:2019+A1:2021, EN 62841-1:2015+A11:2022,  
EN IEC 55014-2:2021, IEC 62321-7-1:2015, IEC 62321-7-2:2017, IEC 62321-3-1:2013,  
IEC 62321-1:2013, IEC 62321-2:2013, IEC 62321-5:2013, IEC 62321-6:2015, ISO 17075-1:2017*

The technical documentation required to demonstrate that the product(s) meet(s) the requirement(s) of the aforementioned legislation has been compiled and is available for inspection by the relevant enforcement authorities.

**The CE mark was first applied in: 2013**

**Product Description:** Rotary Hammer Drill  
**Model Number(s):** CON1200RD  
**Serial/Batch Number:** Refer to product/packaging label  
**Date of Issue:** 26/10/2023

**Signed:**

**J.A Clarke**  
**Director**

# A SELECTION FROM THE VAST RANGE OF

# Clarke®

## QUALITY PRODUCTS



### **AIR COMPRESSORS**

From DIY to industrial, Plus air tools, spray guns and accessories.

### **GENERATORS**

Prime duty or emergency standby for business, home and leisure.

### **POWER WASHERS**

Hot and cold, electric and engine driven - we have what you need

### **WELDERS**

Mig, Arc, Tig and Spot. From DIY to auto/industrial.

### **METALWORKING**

Drills, grinders and saws for DIY and professional use.

### **WOODWORKING**

Saws, sanders, lathes, mortisers and dust extraction.

### **HYDRAULICS**

Cranes, body repair kits, transmission jacks for all types of workshop use.

### **WATER PUMPS**

Submersible, electric and engine driven for DIY, agriculture and industry.

### **POWER TOOLS**

Angle grinders, cordless drill sets, saws and sanders.

### **STARTERS/CHARGERS**

All sizes for car and commercial use.

## **PARTS & SERVICE: 0208 988 7400**

**Parts Enquiries**  
[Parts@clarkeinternational.com](mailto:Parts@clarkeinternational.com)

**Servicing & Technical Enquiries**  
[Service@clarkeinternational.com](mailto:Service@clarkeinternational.com)

SALES: UK 01992 565333 or Export 00 44 (0)1992 565335

**Clarke** INTERNATIONAL Hemnall Street, Epping, Essex CM16 4LG  
[www.clarkeinternational.com](http://www.clarkeinternational.com)